

**International Photonics & Electronics Committee**

# **100G-LR4 Optical Modules with Pilot Tone Functionality Implementation Agreement**

**IPEC-100GPT-IA V1.0**



**IPEC PMD WG**  
**[www.ipec-std.org](http://www.ipec-std.org)**



# **100G-LR4 Optical Modules with Pilot Tone Functionality Implementation Agreement**

**Version 1.0**

**December 22, 2025**

**Implementation Agreement created and approved**

**IPEC**

**[www.ipec-std.org](http://www.ipec-std.org)**

*The International Photonics & Electronics Committee (IPEC) is an international standards organization that is committed to developing open optoelectronic standards and delivering strategic roadmap reports. IPEC focuses on standardizing solutions in optical chips, optical/electrical components, and optical modules. Markets addressed by IPEC include 5G, IoT and AI. The gradual digitalization of these industries and the construction of new infrastructure require standardization. However, current optoelectronic standards are reactive, do not pro-actively motivate strategic investments, and do not address all market segments. Therefore, IPEC will look beyond the work of other standards organizations. IPEC will support the optoelectronic industry for the long term, and address un-met needs of its members.*

*IPEC is open to any interested party who wishes to join. All members have the opportunity to participate in developing all IPEC standards and reports on a non-discriminatory basis. The process of developing these standards and reports is transparent to all members. IPEC is registered in Switzerland.*

# **100G-LR4 Optical Modules with Pilot Tone Functionality Implementation Agreement**

## **Summary**

The objective of this document is to define the transmission protocol for the 100G-LR4 optical modules with pilot tone functionality to ensure interoperability among different vendors. Additionally, this document also defines the fundamental testing methods for verifying the pilot tone functionality.

## **Keywords**

100G-LR4, pilot tone, interoperability, testing methods,

**Working Group: PMD**

---

**TITLE: 100G-LR4 Optical Modules with Pilot Tone Functionality Implementation Agreement**

---

**SOURCE: TECHNICAL EDITOR**

Name: Xia Sheng

Company Name: China Telecommunications Corporation

Email: shengx3@chinatelecom.cn

**SOURCE: TECHNICAL EDITOR**

Name: Hao Liu

Company Name: China Telecommunications Corporation

Email: liuhao3@chinatelecom.cn

**WORKING GROUP CHAIR**

Name: Tom Issenhuth

Company Name: Huawei Technologies Co., Ltd

Email: tissenhuth@outlook.com

**List of Members**

The following companies were members of this project at the release of this specification:

Company
Huawei Technologies Co., Ltd
Zhongtian Communication Technology Co., Ltd.
HG Genuine Optics Tech Co., Ltd.
FiberHome Telecommunication Technologies Co., Ltd.
China Academy of Information and Communications Technology
Accelink Technologies Co., Ltd.
ZTE Corporation
YOFC Yangtze Optical Fibre and Cable Joint Stock Ltd.

**Document Revision History**

Rev	Date	Description
D0.1	2024-12-17	The initial baseline of this IA.
D0.2	2025-09-02	<ol style="list-style-type: none"> <li>1. Add the conception of the pilot tone;</li> <li>2. Add the classification and application code;</li> <li>3. Add the technical requirements including frame structure and register definitions, frame transmission requirements, and some other requirements;</li> <li>4. Add the testing methods for the optical module with pilot tone functionality.</li> </ol>
D0.3	2025-10-22	<ol style="list-style-type: none"> <li>1. Add the wavelength column in Table 4.2;</li> <li>2. Delete the chapter 4.5.4;</li> <li>3. Add the chapter 6 Reference;</li> </ol>

		4. Modify some descriptions.
D1.0	2025-12-05	Draft Version 1.0 after Per Company voting completed.
V1.0	2025-12-22	Released after approval of IPEC's BoD.

# Table of Contents

## Contents

<b>Table of Contents .....</b>	<b>6</b>
<b>List of Figures.....</b>	<b>7</b>
<b>List of Tables.....</b>	<b>7</b>
<b>1 Introduction.....</b>	<b>9</b>
<b>2 Optical Module-based Pilot tone: Basic Concepts and Application Scenarios .....</b>	<b>9</b>
2.1 Concepts .....	9
2.2 Application Scenarios.....	10
<b>3 Classification and Application Code of Optical Modules .....</b>	<b>11</b>
3.1 Classification of Optical Modules .....	11
3.2 Application Code .....	11
<b>4 Technical Requirements for Optical Modules with Pilot Tone Using IIC Interface .....</b>	<b>11</b>
4.1 Overview.....	11
4.2 Basic Requirements for Pilot Tone Signals .....	11
4.3 Frame Structure and Register Definitions.....	13
4.4 Frame Transmission Requirements.....	15
4.4.1 Establish connection .....	16
4.4.2 Sending Data.....	17
4.4.3 Sending Commands .....	17
4.5 Other Requirements .....	19
4.5.1 Password Protection .....	19
4.5.2 Register Definition .....	19
4.5.3 Pilot Tone Channel Remote Soft Loopback Configuration (Optional).....	19
4.5.4 Power Consumption Requirements.....	20
4.5.5 Pilot Tone Transmit and Receive Frame Count Statistics .....	20
<b>5 Testing Methods for Optical Modules with Pilot Tone Functionality.....</b>	<b>21</b>
5.1 Test Environment Requirements .....	21
5.2 Test Equipment Requirements .....	21
5.3 Testing Methods .....	21
5.3.1 Modulation Rate Tolerance Test .....	21

5.3.2 Data Frame Transmission Interval Test .....	22
5.3.3 Pilot Tone Channel Loopback Test .....	23
5.3.4 Pilot Tone Channel BER Test.....	23
<b>6 Reference .....</b>	<b>24</b>

## List of Figures

FIGURE 1 PILOT TONE TECHNOLOGY NETWORK ARCHITECTURE FOR OPTICAL MODULES .....	9
FIGURE 2 CLIENT ACCESS NETWORK APPLICATION. ....	10
FIGURE 3 FRONT-HAUL NETWORK APPLICATION.....	10
FIGURE 4 PILOT TONE ENCODING DIAGRAM FOR OPTICAL MODULES.....	12
FIGURE 5 SIGNAL FLOW OF OPTICAL MODULE WITH PILOT TONE. ....	15
FIGURE 6 DIAGRAM OF COMMUNICATION STATUS REGISTER VALUE CHANGE IN NORMAL OPERATING STATE.....	15
FIGURE 7 OPTICAL MODULE STATE MACHINE.....	15
FIGURE 8 OPTICAL MODULE DATA FRAME TRANSMISSION SEQUENCE AND PERIOD. ....	17
FIGURE 9 MONITORING CHANNEL SOFT LOOPBACK BLOCK DIAGRAM. ....	20
FIGURE 10 MODULATION RATE TOLERANCE TEST SCHEMATIC DIAGRAM. ....	21
FIGURE 11 DATA FRAME TRANSMISSION INTERVAL TEST SCHEMATIC DIAGRAM. ....	22
FIGURE 12 PILOT TONE CHANNEL LOOPBACK TEST SCHEMATIC DIAGRAM.....	23

## List of Tables

TABLE 1 TYPES OF OPTICAL MODULES WITH PILOT TONE FUNCTIONALITY .....	11
TABLE 2 PILOT TONE CHANNEL ALLOCATION FOR OPTICAL MODULES .....	12
TABLE 3 BASIC REQUIREMENTS FOR MODULATED SIGNALS .....	12
TABLE 4 FRAME STRUCTURE AND OPTICAL MODULE ADDRESS UNITS.....	13
TABLE 5 FRAME FORMAT REQUIREMENTS FOR DIFFERENT TYPES OF OPTICAL MODULES.....	13
TABLE 6 FRAME STRUCTURE DEFINITION .....	14
TABLE 7 COMMAND LIST FOR QSFP28 OPTICAL MODULES.....	14
TABLE 8 STATUS FRAME SENT BY THE LOCAL OPTICAL MODULE AFTER BEING READY .....	16
TABLE 9 STATUS FRAME SENT FROM LOCAL-END OPTICAL MODULE TO REMOTE-END .....	16
TABLE 10 EXAMPLE OF SENDING A RESET COMMAND TO THE REMOTE OPTICAL MODULE .....	17

TABLE 11 EXAMPLE OF SENDING A RESET COMMAND TO THE REMOTE OPTICAL MODULE..... 18

TABLE 12 EXAMPLE OF RESPONSE STATUS FRAME AFTER SUCCESSFUL COMMAND RECEPTION (NO RETURN VALUE) ... 18

TABLE 13 EXAMPLE OF RESPONSE COMMAND FRAME AFTER SUCCESSFUL COMMAND RECEPTION (WITH RETURN VALUE) ..... 18

TABLE 14 EXAMPLE OF RESPONSE STATUS FRAME SENT AFTER COMMAND RECEPTION ERROR ..... 18

TABLE 15 QSFP28 OPTICAL MODULE PASSWORD PROTECTION ..... 19

TABLE 16 MODULATION ATTRIBUTES OF OPTICAL MODULE WITH PILOT TONE FUNCTIONALITY FOR QSFP28 ..... 19

TABLE 17 THE FRAME STRUCTURE OF THE LOOPBACK DATA PART ..... 20

## 1 Introduction

This implementation agreement (IA) specifies the transmission protocol for the 100G-LR4 optical module with pilot tone functionality to ensure interoperability among different vendors. Additionally, this document also defines the fundamental testing methods for verifying the pilot tone functionality.

100G-LR4 optical modules can be used in the fiber-direct connection and front-haul semi-active WDM systems scenarios. Two optical modules can communicate over two single mode fibers (SMF) with reach up to at least 10 km. The module electrical interface is not specified by this IA.

## 2 Optical Module-based Pilot tone: Basic Concepts and Application Scenarios

### 2.1 Concepts

The pilot tone technology in optical modules generates operation administration and maintenance (OAM) signals internally, which are superimposed onto the main service signal as low-frequency perturbations. These pilot tone travel along with the high-speed service signals in optical fibers. The generation and detection of the pilot tone are both carried out within the optical module, and under certain conditions, the pilot tone does not interfere with the main service signal. The primary goal is to enable local network management equipment to operate, manage, and maintain remote optical modules. This helps in quickly locating network faults and improving the OAM efficiency of the network.

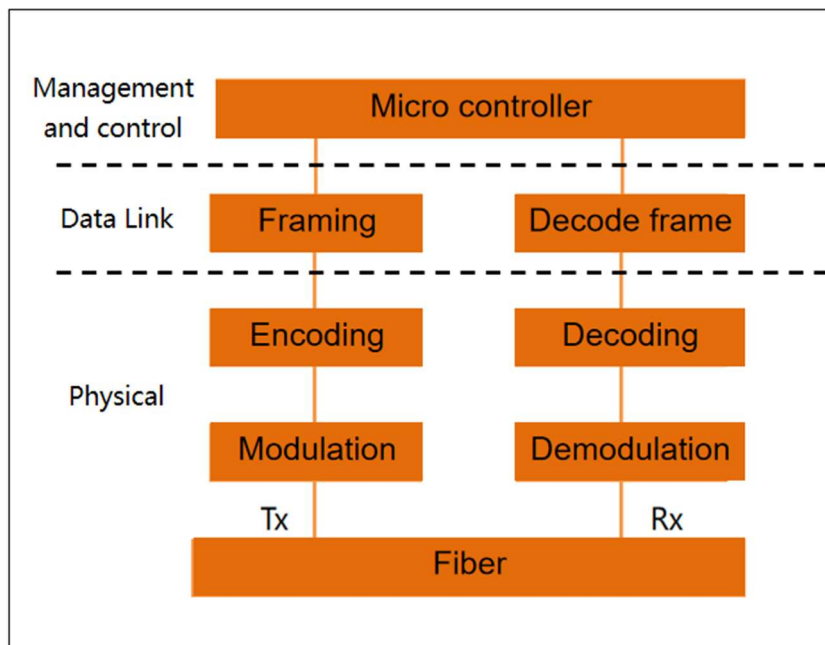

Figure 1 Pilot tone Technology Network Architecture for Optical Modules.

The functional model and basic architecture of pilot tone technology in optical modules is shown in Figure 1. The management control layer serves as the communication channel between the device terminal and the optical module. Through a standard low-speed management interface, the device terminal sends pilot tone commands to the optical module and extracts pilot tone data stored inside the module. The controller unit, located within the optical module, analyzes and processes the pilot tone in real-time. The pilot tone are transmitted at the link layer using data framing techniques, ensuring reliable transmission through traffic control, error detection, and retransmission mechanisms. The physical layer handles the encoding and decoding of pilot tone frames, as well as modulation and demodulation, ensuring that the pilot tone are transmitted together with the main service signals in the optical fiber without loss of integrity.

## 2.2 Application Scenarios

Optical modules with pilot tone functionality can be widely deployed in base stations or central offices. These modules meet the demand for remote optical module management and control through local devices in scenarios such as fiber direct connections or WDM systems. They are primarily applicable in the following scenarios:

- (1) Fiber direct connection: remote client equipment with optical modules and client-side gray optical modules in central office equipment (As shown in Figure 2) .
- (2) Front-haul semi-active WDM Systems: the colored optical modules on remote devices (AAU/RRU) and central office equipment (DU/BBU) (As shown in Figure 3) .

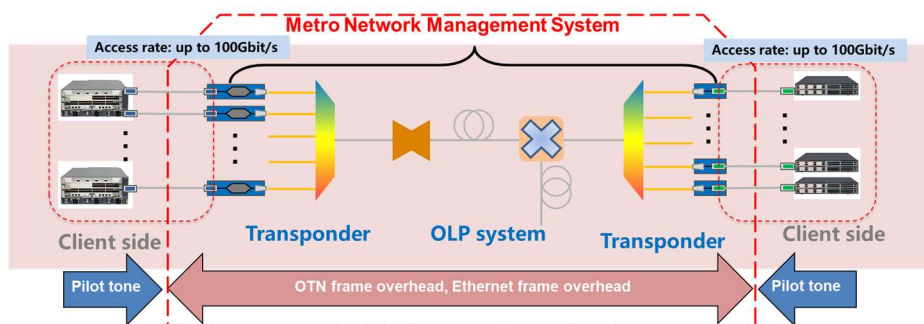

Figure 2 Client Access Network Application.

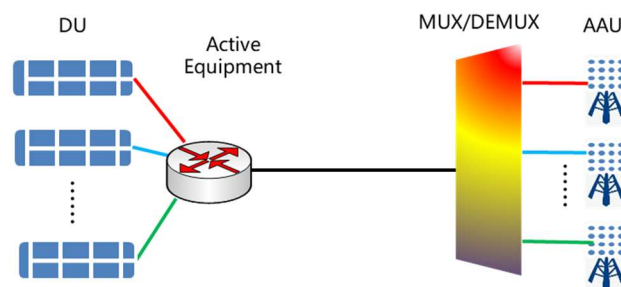

Figure 3 Front-haul Network Application.

### 3 Classification and Application Code of Optical Modules

#### 3.1 Classification of Optical Modules

Optical modules with pilot tone functionality should conform to the requirements specified in the normative reference documents, in accordance with the IEEE 802.3-2022<sup>1</sup>. The main types of optical modules applicable to this standard are listed in Table 1.

Table 1 Types of Optical Modules with Pilot Tone Functionality

Type of the module	Number of channels	Pilot tone channel allocation	Rate per lane	Interface	Code	Classification Reference Standards
100G QSFP28 LR4	4	Lane 3	28Gbit/s	IIC	NRZ	IEEE 802.3-2022

#### 3.2 Application Code

The application code for optical modules with pilot tone functionality should add the character "(P)" at the end to indicate that the optical module supports pilot tone functionality. For example:

A 4-channel 100Gbit/s QSFP28 optical module with pilot tone functionality, if the specification is 10 km, would have the application code: 100GBASE-LR4 (P).

### 4 Technical Requirements for Optical Modules with Pilot Tone Using IIC Interface

#### 4.1 Overview

The optical module with pilot tone functionality should have the following requirements: the pilot tone function should be enabled by default after power-on. The optical module at both ends of the link should automatically establish a connection. The steps for connection establishment can be found in Section 4.4.1. The transmission method for the pilot tone signal is described in Section 4.4.

The optical module needs to support the enable/disable switch for the pilot tone functionality. For QSFP28 modules, the equipment is set through a 128-Byte field at device bus address A0h, Page 30h, with 0x00 for enabling and 0x01 for disabling. The management interface protocols follow the SFF-8472<sup>2</sup> and SFF-8636<sup>3</sup> standards.

#### 4.2 Basic Requirements for Pilot Tone Signals

The pilot tone signal is generated using low-frequency modulation. For multi-channel optical modules, both the transmitting and receiving sides use specified wavelength channels to transmit the monitoring signals. Table 2

defines the channels used for pilot tone in multi-channel optical modules, with each module type using a unique sub-channel.

Table 2 Pilot Tone Channel Allocation for Optical Modules

Type of the module	Number of channels	Pilot tone channel allocation	Wavelength
100G QSFP28 LR4	4	Lane 3	1310nm

The '1' and '0' of the pilot tone signal use a unified fixed-pattern balanced encoding (i.e., Manchester encoding), with the signal waveform diagram shown in Figure 4.

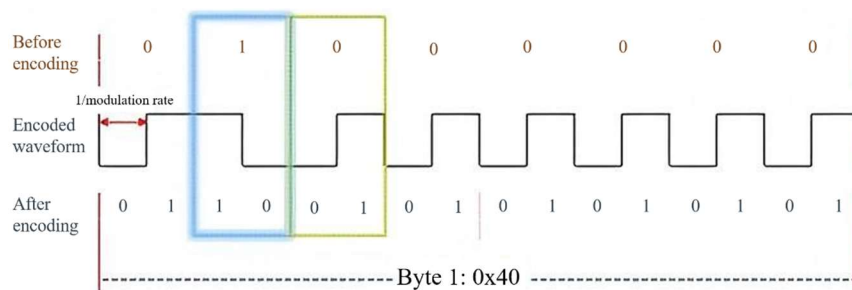

Figure 4 Pilot Tone Encoding Diagram for Optical Modules.

The pilot tone signal, during both transmission and reception, should not interfere with the normal communication of the local IIC interface.

The key parameter requirements for the pilot tone signal in optical modules using the IIC interface are listed in Table 3.

Other modulation schemes are subject to further research.

Table 3 Basic Requirements for Modulated Signals

Parameters	Min. value	Typical value	Max. value	Unit
Modulation depth <sup>a</sup>	3		5	%
Encoding		Manchester Code		
Rate after encoding		1024		bps
Penalty <sup>b</sup>		0.5		dB
OAM sensitivity		-5		dBm
<p>a. The modulation depth is defined as <math>\frac{P(1)-P(0)}{P(1)+P(0)}</math>, where P(1) is represents the average optical power when the modulation signal is "1" and P(0) is represents the average optical power when the modulation signal is "0" ;</p> <p>b. The penalty is defined as the degradation of the receiving sensitivity of the business signal caused by the pilot tone signals.</p> <p>c. The max sensitivity of the business signal when the maximum BER is 1E-6</p>				

### 4.3 Frame Structure and Register Definitions

The pilot tone signal is transmitted in frames over the channel. The channel remains idle between frames, during which no pilot tone signal is transmitted.

A fixed-length frame structure is used (see Table 4), with a frame length of 30 Bytes. The first 5 Bytes are the prefix (0x40), and the last Byte is the suffix (0x7F). CRC-8 is used to check the remaining Bytes.

For QSFP28 optical modules, the pilot tone frame information (frame type, local status, remote status, label, command ID, command parameters, dual-wire address, and starting address) is stored in Page 30h, Bytes 129-136 of the A0h device address.

The transmission and reception of frames are classified into three types based on their function: status frames, command frames, and data frames. Each type of frame requires different addresses (see Table 5), with unused addresses filled with 0x00. The symbol "√" indicates an address that must be used, "○" indicates an address that may be used in certain cases, and "-" indicates an address that is not required. The detailed definition of the frame structure is provided in Table 6.

Table 4 Frame Structure and Optical Module Address Units

Type	Prefix	Frame type	Status	Label	Command ID	Command parameter	Page Selection	Starting address	Data (16 Bytes)	CRC-8	Suffix
Length (Unit: Byte)	5	1	1	1	1	1	1	1	16	1	1

Table 5 Frame Format Requirements for Different Types of Optical Modules

Type	Prefix	Frame type	Status	Label	Command ID	Command parameter	Page Selection	Starting address	Data (16 Bytes)	CRC-8	Suffix
Status frame	✓	✓	✓	✓	-	-	-	-	-	✓	✓
Data frame	✓	✓	✓	✓	-	-	✓	✓	✓	✓	✓
Command frame	✓	✓	✓	✓	✓	✓	○	○	○	✓	✓

The definitions of the commands sent from the local-end optical module to the remote-end in command mode, which require an immediate response from the remote end, are described in Table 7. Unless specified otherwise, all commands have default parameters set to 0x00. For command frames that require a response (data return), such as those with ID 0x10 or 0x40, the returned data is written into the data section of the frame structure and sent back as a command frame, with the command parameter set to 0xFF.

Table 6 Frame Structure Definition

Name	Bit	Definition	Description	Default
Prefix	Bit7~Bit0	Used for clock synchronization	Fixed value	0x40
Frame type	Bit7~Bit6	Data expansion status (only effective when transmitting data)	01: Data transmission 10: Data reception error	00b
	Bit5~Bit4	Command extension status (only effective in send command mode)	01: Command sending request 10: Command received successfully 11: Command reception error	00b
	Bit3~Bit2	Transmission mode	01: Transmission data mode 10: Send command mode	01b
	Bit1~Bit0	Frame type	01: Status frame 10: Data frame 11: Command frame	01b
Status	Bit7~Bit0	The state during pilot tone signal transmission	0x01: Local module ready 0x02: Remote module ready 0x04: Normal state 0x08: Reception error 0x80: Link error	0x01
Label	Bit7~Bit0	Identification	The definitions are provided in section 4.5.4.	-
Command ID	Bit7~Bit0	Command ID	The list of commands is provided in Table 7	0x00
Command parameters	Bit7~Bit0	Command parameter settings		0x00
Page Selection	Bit7~Bit0	IIC device bus selection	IIC device bus address, such as A0h, A2h	0xA0
Starting address	Bit7~Bit0	Starting register address for data transmission	Starting address of data	0x00
Data	Bit7~Bit0	Data	Data Byte segment	0x00
CRC	Bit7~Bit0	CRC-8/CCITT	The polynomial $x^8 + x^2 + x + 1$ , XOR with 0x00 and without reversal	0x00
End	Bit7~Bit0	The end of frame	Default value	0x7F

Table 7 Command List for QSFP28 Optical Modules

Command ID	Description	Definition	Notes
0x00	Idle		
0x01	Remote module reset	0x01: Reset	
0x02	Turn off the remote optical module laser	Set laser shutdown time	$(n+1)*1s, n=[0,255]$
0x03	Remote optical module business path loopback setting	0x01: Internal loop 0x10: External loop 0x00: Cancel loopback	
0x04-0x0B	Turn off the remote optical module sub channel laser	Set laser shutdown time, corresponding to Lane0~Lane7	$(n+1)*1s, n=[0,255]$
0x0C-0x0F	RES	-	-
0x10	Read remote optical module in-service OAM status	0x01	-
0x11	Set remote-end data frame transmission interval	Default 0x00: 80ms	$(n+1) \times 1s, n=[0,255]$
0x12	Set shallow loopback time for OAM path at remote end	Minimum unit 1 minute (LSB)	Loopback definition in section 7.5.3
0x13	Set deep loopback for OAM path at remote end	-	
0x14	Send data in loopback mode for OAM path	-	Data frame definition in section 7.5.3
0x15-0x2F	RES	-	-
0x30	Write values to the remote module register		
0x31-0x3F	RES		
0x40	Read up to 16 bytes continuously from the remote module	0xM: Read M bytes	
0x41-0xFF	RES	-	-

#### 4.4 Frame Transmission Requirements

The signal flow of pilot tone within the optical module is shown in Figure 5. The transmission of pilot tone can be divided into three stages, each with a different frame format. Details of these stages are described in Sections 4.4.1 to 4.4.3. Figure 6 illustrates the communication state register value transitions during pilot tone frame transmission under normal operation. The local status information of pilot tone is stored in the status register and written into the status Byte of the frame structure for in-band transmission. If either end receives an incomplete frame, it will be discarded. The state machine for pilot tone signals is detailed in Figure 7, where "08h" and "80h" represent failure states, indicating a fault at the receiving end, which does not affect the transmitting end. The pilot tone state should be stored in the specified register as per the requirements in Section 4.3.

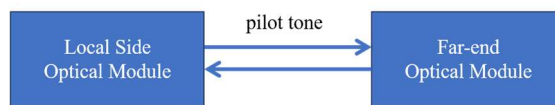

Figure 5 Signal Flow of Optical Module with Pilot Tone.

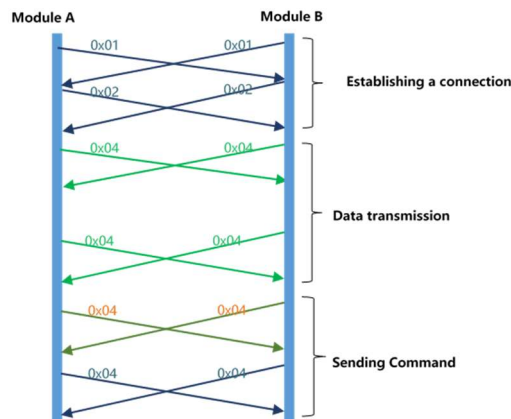

Figure 6 Diagram of Communication Status Register Value Change in Normal Operating State.

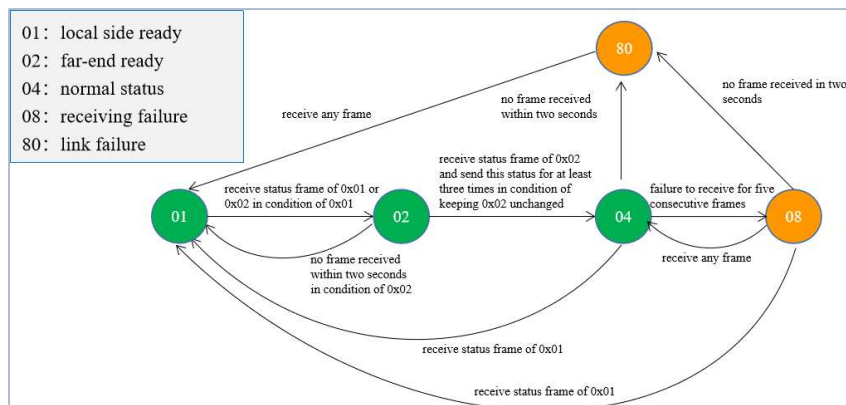

Figure 7 Optical Module State Machine.

#### 4.4.1 Establish connection

The optical module with pilot tone functionality automatically activates the monitoring channel upon power-up. When the local module detects that the module initialization is complete, the state machine enters state 01h and begins transmitting a status frame with the communication status register set to 0x01. The state machine will only transition to state 02h and send a status frame with the communication status register set to 0x02 upon receiving a status frame with the communication status register set to 0x01 or 0x02 from the remote end. In states 0x01 and 0x02, the optical module will transmit status frames containing its own status information. If initialization is not complete, indicating that the module is either still starting up or has encountered a fault, the state will be 00h.

The connection establishment process is as follows: (\* indicates an abnormal mode. When the optical module detects an anomaly, appropriate handling is required to ensure that the pilot tone transmission mechanism remains uninterrupted, and the same applies hereafter)

1) The local optical module detects the status as 01h and begins to autonomously send the 0x01 status frame to the remote end.

Table 8 Status Frame Sent by the Local Optical Module After Being Ready

Type	Prefix	Frame type	Status	Label	Idle	CRC-8	Suffix
Length (Unit: Byte)	5	1	1	1	20	1	1
Value (HEX)	0x40	0x05	0x01	0x00	0x00		0x7F

2) The remote optical module receives the transmitted status frame, updates the status to 02h, and sends a 0x02 status frame.

Table 9 Status Frame Sent from Local-end Optical Module to Remote-end

Type	Prefix	Frame type	Status	Label	Idle	CRC-8	Suffix
Length (Unit: Byte)	5	1	1	1	20	1	1
Value (HEX)	0x40	0x05	0x02	0x00	0x00		0x7F

3) When the optical module in state 01h receives the 0x02 status frame, it updates the state to 02h and sends a status frame. When the optical module in state 02h receives the 0x02 status frame, it updates the state to 04h and starts sending data frames.

4) \*If the optical module in state 02h does not receive the 0x02 status frame within 2 seconds, the state will revert to 01h.

#### 4.4.2 Sending Data

After the connection is established and the state is 04h, the optical module starts sending data frames to the remote end. The default interval between frame transmissions is 80ms (configurable).

The data transmission sequence is shown in Figure 8. For QSFP28 optical modules, the entire contents of A0h are sent once every 10 minutes, and the Bytes 1 to 16, 20 to 27, and 34 to 57 of A0h are then transmitted cyclically in three separate transmissions.

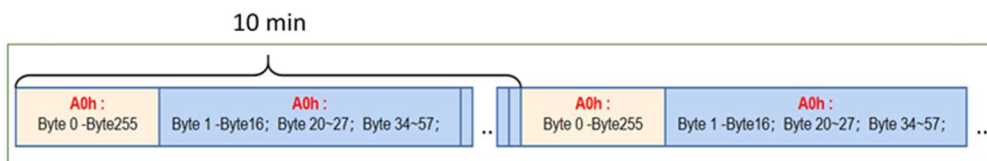

Figure 8 Optical Module Data Frame Transmission Sequence and Period.

1) According to the requirements of Figure 8, the optical module first sends a data frame with Bytes 0 to 15 of A0h Page00h. Once the remote end successfully receives it, the data is written into Bytes 0 to 15 of A0h Page00h in the optical module's address E0h Page00h. The register addresses and definitions of A0h/A2h are identical to those of E0h/E2h.

Table 10 Example of Sending a Reset Command to the Remote Optical Module

Type	Prefix	Frame type	Status	Label	Idle	Page Selection	Starting address	Data (16 Bytes)	CRC-8	Suffix
Length (Unit: Byte)	5	1	1	1	2	1	1	16	1	1
Value(HEX)	0x40	0x46	0x04	0x00	0x00	0xA0	0x00	Byte 0-Byte 15		0x7F

- 2) \*If 5 consecutive reception errors occur, the receiving side's status changes to 08h.
- 3) \*If no frame is received within 2 seconds, the receiving side's status changes to 80h.

#### 4.4.3 Sending Commands

According to the requirements in Table 7, when the optical module is in the 04h state and has completed password writing (see Sections 4.5.1), it can send a command request to the remote optical module for operation. Specifically, the host side writes the command ID and command parameters to Bytes 133-134 of Page 30h in the optical module via the standard IIC interface, and executes the command by writing to Byte 133 of Page 30h, which is the last Byte of the entire message. For commands with return values (such as command ID = 0x40), after successful reception, there is no need to send a response status frame; instead, the command frame carrying the data will be returned. Once in command-send mode, only one command is sent at a time.

- 1) In command-send mode, write "01b" to bits 5-4 of Byte 129 on Page 30h to send the command frame.

Table 11 Example of Sending a Reset Command to the Remote Optical Module

Type	Prefix	Frame type	Status	Label	Command ID	Command parameter	Idle	CRC-8	Suffix
Length (Unit: Byte)	5	1	1	1	1	1	18	1	1
Value(HEX)	0x40	0x1B	0x04	0x00	0x01	0x01	0x00		0x7F

2) When the optical module receives a correct command frame that does not require a return value, it temporarily suspends data transmission, continuously sending 5 successful response status frames to acknowledge the receipt of the command, and then executes the command. If the optical module receives a command frame that requires a return value, it continuously returns 5 response command frames carrying the data.

Table 12 Example of Response Status Frame After Successful Command Reception (No Return Value)

Type	Prefix	Frame type	Status	Label	Idle	CRC-8	Suffix
Length (Unit: Byte)	5	1	1	1	20	1	1
Value (HEX)	0x40	0x29	0x04	0x00	0x00		0x7F

Table 13 Example of Response Command Frame After Successful Command Reception (With Return Value)

Type	Prefix	Frame type	Status	Label	Command ID	Command parameter	Data	Idle	CRC-8	Suffix
Length (Unit: Byte)	5	1	1	1	1	1	1	15	1	1
Value (HEX)	0x40	0x2A	0x04	0x00	0x10	0xFF	0x04	0x00		0x7F

3) \*When the optical module receives an incorrect command frame, it will continuously send 5 error response status frames to indicate that the command transmission has failed.

Table 14 Example of response status frame sent after command reception error

Type	Prefix	Frame type	Status	Label	Idle	CRC-8	Suffix
Length (Unit: Byte)	5	1	1	1	20	1	1
Value (HEX)	0x40	0x39	0x04	0x00	0x00		0x7F

4) \*If the optical module does not receive the command frame, it will remain in data transmission mode. If the sending side checks the bit 5-4 of Byte 129 in Page 30h within 5 seconds and finds that it is still "01b," this indicates a connection timeout, and the module will exit command sending mode.

## 4.5 Other Requirements

### 4.5.1 Password Protection

Optical modules with pilot tone functionality should support password protection. For QSFP28 optical modules, Bytes 119-122 of A0h are the password modification area, and Bytes 123-126 are the password writing area, as shown in Table 15. Only after writing the correct ASCII code to Bytes 123-126 can commands be sent to the remote optical module.

Table 15 QSFP28 Optical Module Password Protection

Name	Change Password				Write password			
A0h (Byte)	119	120	121	122	123	124	125	126

### 4.5.2 Register Definition

For QSFP28 optical modules, the modulation attributes of the optical module with pilot tone functionality are defined in Byte 251 of Page 01h in A0h (see Table 16).

Table 16 Modulation Attributes of optical module with pilot tone functionality for QSFP28

Address	Bit	Name
251	Bit7~Bit6	Modulation method: 01b Single carrier amplitude modulation
	Bit5~Bit4	Modulation rate Fm setting (typical value): 01b: Fm≤1Kbps 10b: 1Kbps<Fm≤10Kbps 11b: Fm>10Kbps
	Bit3~Bit0	Reserved bits

### 4.5.3 Pilot Tone Channel Remote Soft Loopback Configuration (Optional)

The in-service optical module with pilot tone functionality optionally supports internal monitoring path loopback configuration. Loopback 1 refers to a shallow loopback, where the data received by the remote optical module is not decoded but is passed back to the local optical module via the transmitting side. Loopback 2 refers to a deep loopback, where the data goes through decoding/encoding processing before being looped back. The loopback paths are shown in Figure 9.

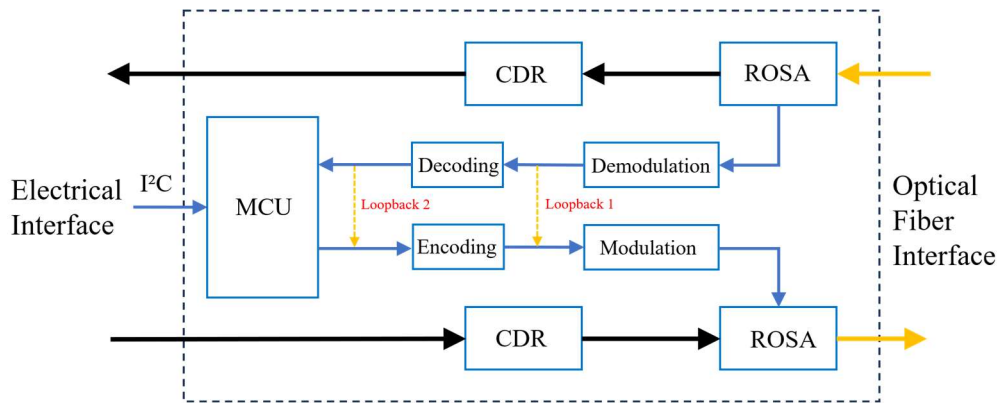

Figure 9 Monitoring Channel Soft Loopback Block Diagram.

After the remote optical module successfully sets the loopback, the normal monitoring channel will be interrupted, and the data transmitted by the local optical module will be sent and received by itself. Using Page 30h, Bytes 192–207, up to 16 Bytes of data can be written, and Bytes 208–223 store the data after it has gone through the loopback.

In loopback mode, after a command is issued by the management layer, the data in Bytes 192–207 will be transmitted by the local optical module once. The frame structure of the loopback data part is as follows:

Table 17 The Frame Structure of the Loopback Data Part

Name	Data(16 Bytes)
Send Data Write Address	192~207
Receive Data Storage Address	208~223
Value	Custom (User-defined data)

When the set loopback time is automatically reached, the remote optical module will automatically cancel the loopback, and the normal monitoring channel will be restored.

#### 4.5.4 Power Consumption Requirements

The optical modules with pilot tone functionality should meet the power consumption requirements specified by the industry or international standards for optical modules of the same packaging type.

#### 4.5.5 Pilot Tone Transmit and Receive Frame Count Statistics

The optical modules with pilot tone functionality must support the statistical tracking of transmitted and received pilot tone frames.

For QSFP28 type optical modules:

- The total number of transmitted frames is stored in Page 30h, Byte 144 to Byte 147 at the A0h device address.
- The number of successfully received frames is stored in Page 30h, Byte 148 to Byte 151.
- The number of erroneous received frames is stored in Page 30h, Byte 152 to Byte 155. All these registers are readable and writable.

All pilot tone transmit and receive frame statistics occupy four continuous Bytes and use a 32-bit unsigned number, where the low address represents the least significant Byte (LSB). The counting is done in an accumulating manner.

## 5 Testing Methods for Optical Modules with Pilot Tone Functionality

### 5.1 Test Environment Requirements

The test environment requirements are as follows:

- Temperature: 15°C to 35°C;
- Relative humidity: 45% to 75%;
- Atmospheric pressure: 86 kPa to 106 kPa.

If testing cannot be conducted under standard atmospheric pressure conditions, the test report should specify the environmental conditions.

### 5.2 Test Equipment Requirements

The instruments and equipment used for testing should be within the specified valid calibration period. Unless otherwise specified, their accuracy should be at least one order of magnitude higher than the accuracy of the measured parameters.

### 5.3 Testing Methods

#### 5.3.1 Modulation Rate Tolerance Test

##### Test Block Diagram:

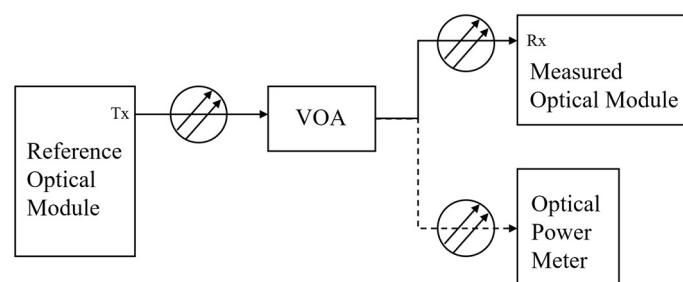

Figure 10 Modulation rate tolerance test schematic diagram.

**Test Steps:**

- 1) Enable the pilot tone function of the optical module, adjust the variable attenuator, and measure the optical power reading using an optical power meter to reach the maximum pilot tone sensitivity specification. Inject light of equal intensity into the Rx port of the optical module under test.
- 2) Keep the pilot tone channel in data transmission mode, and use software on the transmitting side to gradually increase the signal modulation rate until the receiving side fails to receive pilot tone data. Then, decrease the modulation rate, and the pilot tone channel on the receiving side will resume normal operation. Record the modulation rate at the critical point as the upper limit of the modulation rate.
- 3) Keep the pilot tone channel in data transmission mode, and use software on the transmitting side to gradually decrease the signal modulation rate until the receiving side fails to receive pilot tone data and reports a link failure. Then, increase the modulation rate, and the pilot tone channel on the receiving side will resume normal operation. Record the modulation rate at the critical point as the lower limit of the modulation rate.
- 4) Adjust the variable attenuator and measure the optical power reading using an optical power meter to reach the optical module’s overload point. Inject light of equal intensity into the Rx port of the optical module under test. Repeat steps 3) and 4).

5.3.2 Data Frame Transmission Interval Test

**Test Block Diagram:**

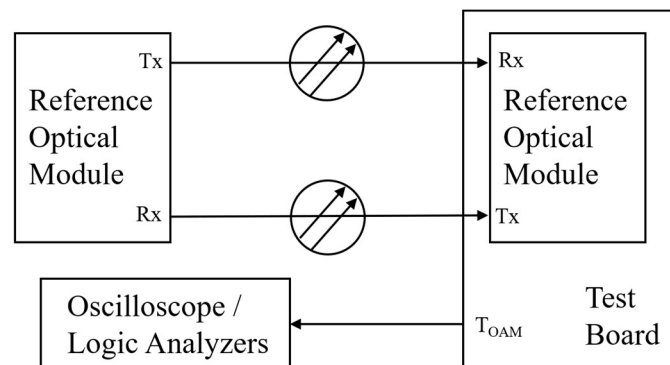

Figure 11 Data frame transmission interval test schematic diagram.

**Test Steps:**

- 1) Maintain the pilot tone channel in normal data frame transmission mode. Connect the frame transmit port ( $T_{OAM}$ ) of the module under test to a channel of an oscilloscope or logic analyzer. Record the time interval between two consecutive frames.

2) Modify the data frame transmission interval by adjusting the reference module's settings. Record the time interval between two consecutive frames on the module under test.

### 5.3.3 Pilot Tone Channel Loopback Test

**Test Block Diagram:**

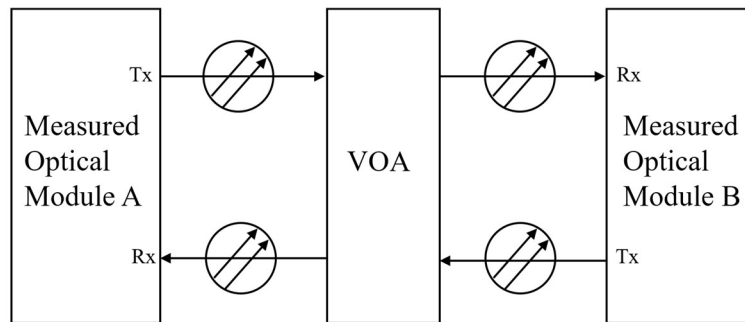

Figure 12 pilot tone channel loopback test schematic diagram.

**Test Steps:**

- 1) Adjust the variable optical attenuator to ensure that the received optical power at both tested modules remains close to the pilot tone sensitivity point.
- 2) Ensure the pilot tone channel is in normal communication status and send the pilot tone channel loopback command from optical module B to optical module A. During the loopback, optical module B continuously sends custom verification packets. On the local side, verify the consistency between transmitted and received packets.
- 3) Keep the pilot tone channel in normal communication status and send the pilot tone channel loopback command from optical module A to optical module B. During the loopback, optical module A continuously sends custom verification packets. On the local side, verify the consistency between transmitted and received packets.

### 5.3.4 Pilot Tone Channel BER Test

**Test Block Diagram:**

Same as Figure 10

**Test Steps:**

- 1) Keep the pilot tone channel in the data transmission state, adjust the variable optical attenuator, and use an optical power meter to measure the optical power reading, ensuring it reaches the maximum pilot tone sensitivity specification. Input light of equal strength into the Rx port of the module under test.

- 2) Start timing from any moment of data frame transmission from the reference module, and record the frame loss rate (BER) of the module under test over a continuous period.
- 3) Change the attenuation of the variable optical attenuator, and start timing from any moment of data frame transmission from the reference module, then record the frame loss rate (BER) of the module under test over a continuous period.

## **6 Reference**

1. IEEE, IEEE Standard for Ethernet, IEEE Std 802.3™-2022, 2022
2. SFF Committee, Management Interface for SFP+, SFF-8472, 2025
3. SFF Committee, Management Interface for 4-lane Modules and Cables, SFF-8636,2023



Email: [info@ipec-std.org](mailto:info@ipec-std.org)

Website: [www.ipec-std.org](http://www.ipec-std.org)

COPYRIGHT© 2025 IPEC. All rights reserved.